

USER'S MANUAL

Micra 100 WI-FI



HEAT RECOVERY AIR HANDLING UNIT

CONTENTS

Purpose.....	5
Delivery set.....	5
Designation key.....	5
Technical data.....	6
Design and operating principle	7
Installation and set-up.....	8
Connection to power mains	12
Control	13
Technical maintenance.....	17
Troubleshooting.....	18
Storage and transportation regulations.....	18
Manufacturer's warranty	19
Certificate of acceptance.....	21
Seller information.....	21
Installation certificate.....	21
Warranty card.....	21

This user's manual is a main operating document intended for technical, maintenance, and operating staff.

The manual contains information about purpose, technical details, operating principle, design, and installation of the Micra100 Wi-Fi unit and all its modifications.

Technical and maintenance staff must have theoretical and practical training in the field of ventilation systems and should be able to work in accordance with workplace safety rules as well as construction norms and standards applicable in the territory of the country.

This unit is not intended for use by persons (including children) with reduced physical, sensory or mental capabilities, or lack of experience and knowledge, unless they have been given supervision or instruction concerning use of the unit by a person responsible for their safety. Children should be supervised to ensure that they do not play with the unit.

This appliance can be used by children aged from 8 years and above and persons with reduced physical, sensory or mental capabilities or lack of experience and knowledge if they have been given supervision or instruction concerning use of the appliance in a safe way and understand the hazards involved.

Cleaning and user maintenance shall not be made by children without supervision.

Children shall not play with the appliance.

Connection to the mains must be made through a disconnecting device, which is integrated into the fixed wiring system in accordance with the wiring rules for design of electrical units, and has a contact separation in all poles that allows for full disconnection under overvoltage category III conditions.

Ensure that the unit is switched off from the supply mains before removing the guard.

Precautions must be taken to avoid the back-flow of gases into the room from the open flue of gas or other fuel-burning appliances.

The appliance may adversely affect the safe operation of appliances burning gas or other fuels (including those in other rooms) due to back flow of combustion gases. These gases can potentially result in carbon monoxide poisoning. After installation of the unit the operation of flued gas appliances should be tested by a competent person to ensure that back flow of combustion gases does not occur.

All operations described in this manual must be performed by qualified personnel only, properly trained and qualified to install, make electrical connections and maintain ventilation units.

Do not attempt to install the product, connect it to the mains, or perform maintenance yourself. This is unsafe and impossible without special knowledge.

Disconnect the power supply prior to any operations with the unit.

All user's manual requirements as well as the provisions of all the applicable local and national construction, electrical, and technical norms and standards must be observed when installing and operating the unit.

Disconnect the unit from the power supply prior to any connection, servicing, maintenance, and repair operations.

Connection of the unit to power mains is allowed by a qualified electrician with a work permit for the electric units up to 1000 V after careful reading of the present user's manual.

Check the unit for any visible damage of the impeller, the casing, and the grille before starting installation. The casing internals must be free of any foreign objects that can damage the impeller blades.

While mounting the unit, avoid compression of the casing! Deformation of the casing may result in motor jam and excessive noise.

Misuse of the unit and any unauthorised modifications are not allowed.

Do not expose the unit to adverse atmospheric agents (rain, sun, etc.).

Transported air must not contain any dust or other solid impurities, sticky substances, or fibrous materials.

Do not use the unit in a hazardous or explosive environment containing spirits, gasoline, insecticides, etc.

Do not close or block the intake or extract vents in order to ensure the efficient air flow.

Do not sit on the unit and do not put objects on it.

The information in this user's manual was correct at the time of the document's preparation.

The Company reserves the right to modify the technical characteristics, design, or configuration of its products at any time in order to incorporate the latest technological developments.

Never touch the unit with wet or damp hands.

Never touch the unit when barefoot.

BEFORE INSTALLING ADDITIONAL EXTERNAL DEVICES, READ THE RELEVANT USER MANUALS.



THE PRODUCT MUST BE DISPOSED SEPARATELY AT THE END OF ITS SERVICE LIFE.

DO NOT DISPOSE THE UNIT AS UNSORTED DOMESTIC WASTE

PURPOSE

The unit is designed to ensure continuous mechanical air exchange in houses, offices, hotels, cafes, conference halls, and other utility and public spaces as well as to recover the heat energy contained in the air extracted from the premises to warm up the filtered stream of intake air.

The unit is not intended for organizing ventilation in swimming pools, saunas, greenhouses, summer gardens, and other spaces with high humidity.

Due to the ability to save heating energy by means of energy recovery, the unit is an important element of energy-efficient premises.

The unit is a component part and is not designed for stand-alone operation. It is rated for continuous operation.

Transported air must not contain any flammable or explosive mixtures, evaporation of chemicals, sticky substances, fibrous materials, coarse dust, soot and oil particles or environments favourable for the formation of hazardous substances (toxic substances, dust, pathogenic germs).

DELIVERY SET

NAME	NUMBER
Air handling unit	1 pc.
User's manual	1 pc.
Mounting template	1 pc.
Fastening kit	1 pc.
Magnetic sheet	1 pc.
Key	1 pc.
Spigot	1 pc.
Packing box	1 pc.

DESIGNATION KEY

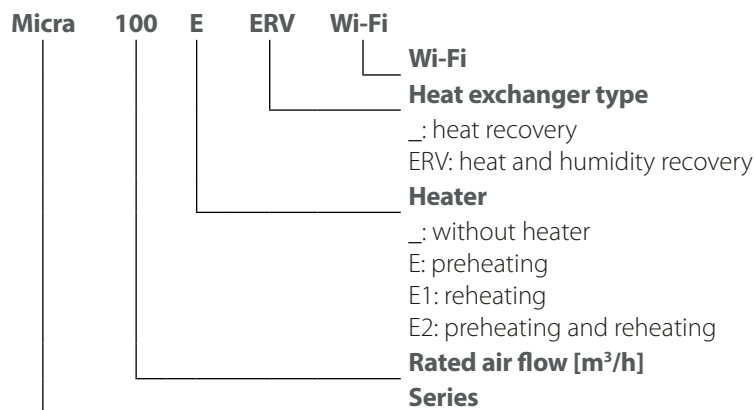

TECHNICAL DATA

The unit is designed for indoor application with the ambient temperature ranging from +1 °C up to +40 °C and relative humidity up to 60 % without condensation. In cold, damp rooms, there is a possibility of freezing or condensation inside and outside the casing. In order to prevent condensation on the internal walls of the unit, it is necessary that the surface temperature of the casing is 2-3 °C above the dew point temperature of the transported air.

The unit should be operated continuously, and in cases where ventilation is not necessary, reduce the air flow of the fans to a minimum (20%). This will ensure a favorable indoor climate and reduce the amount of condensation inside the unit, which can damage electronic components. Never use the unit for dehumidification, for example, of new buildings.

The unit is rated as a Class I electrical appliance.

Hazardous parts access and water ingress protection rating:

IP22 for the unit connected to the air ducts

IP44 for the unit motors

The unit design is constantly being improved, thus some models may be slightly different from those described in this manual.

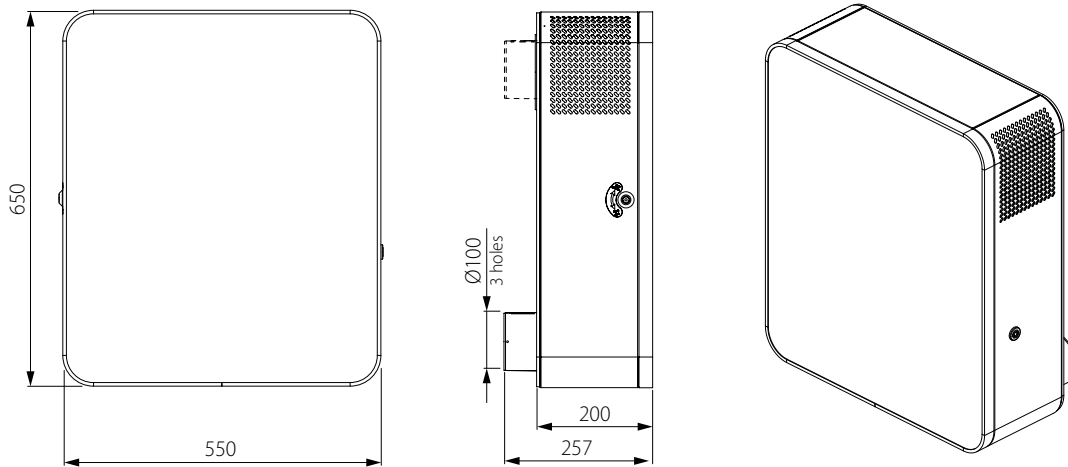

 **THE EXTRACT AIR TEMPERATURE SHOULD BE NO HIGHER THAN +40 °C AND RELATIVE HUMIDITY SHOULD NOT EXCEED 70 % OVER THE ENTIRE TEMPERATURE RANGE.**

Parameter	Micra 100 Wi-Fi					Micra 100 E Wi-Fi					Micra 100 E1 Wi-Fi					Micra 100 E2 Wi-Fi								
	30	44	60	75	100	30	44	60	75	100	30	44	60	75	100	30	44	60	75	100				
Maximum air capacity [m³/h]	30	44	60	75	100	30	44	60	75	100	30	44	60	75	100	30	44	60	75	100				
Supply voltage [V/50 (60) Hz]	1~ 110-240					1~ 230					1~ 230					1~ 230								
Maximum fan power [W]	20	23	29	37	53	20	23	29	37	53	20	23	29	37	53	20	23	29	37	53				
Sound pressure level at 3 m distance [dBA]	13	20	27	33	39	13	20	27	33	39	13	20	27	33	39	13	20	27	33	39				
Electric heater power [W]	preheating					700					-					700								
	reheating					-					350					350								
Maximum unit current [A]	without an electric heater					0.4					0.4					0.4								
	with an electric heater					-					3.6					1.94					5.2			
Transported air temperature [°C]	from -20 up to +40																							
Casing material	painted steel																							
Insulation	foam rubber, 10 mm																							
Heat recovery efficiency [%]	98	95	92	90	89	98	95	92	90	89	98	95	92	90	89	98	95	92	90	89				
Heat exchanger type	counter-flow																							
Heat exchanger material	polystyrene																							
Supply filter	G4, F8 (option: F8 Carbon, H13)					G4, F8 (option: F8 Carbon, H13)					G4					G4								
Extract filter	G4																							
Connected air duct diameter [mm]	Ø 100																							
Weight [kg]	31					31					31					31								

Parameter	Micra 100 ERV Wi-Fi					Micra 100 E ERV Wi-Fi					Micra 100 E1 ERV Wi-Fi					Micra 100 E2 ERV Wi-Fi								
	30	44	60	75	100	30	44	60	75	100	30	44	60	75	100	30	44	60	75	100				
Maximum air capacity [m ³ /h]	30	44	60	75	100	30	44	60	75	100	30	44	60	75	100	30	44	60	75	100				
Supply voltage [V/50 (60) Hz]	1~ 110-240					1~ 230					1~ 230					1~ 230								
Maximum fan power [W]	20	23	29	37	53	20	23	29	37	53	20	23	29	37	53	20	23	29	37	53				
Sound pressure level at 3 m distance [dBA]	13	20	27	33	39	13	20	27	33	39	13	20	27	33	39	13	20	27	33	39				
Electric heater power [W]	preheating					700					-					700								
	reheating					-					350					350								
Maximum unit current [A]	without an electric heater					0.4					0.4					0.4								
	with an electric heater					-					3.6					1.94					5.2			
Transported air temperature [°C]	from -20 up to +40																							
Casing material	painted steel																							
Insulation	foam rubber, 10 mm																							
Heat recovery efficiency [%]	96	94	89	85	83	96	94	89	85	83	96	94	89	85	83	96	94	89	85	83				
Heat exchanger type	counter-flow																							
Heat exchanger material	enthalpy membrane																							
Supply filter	G4, F8 (option: F8 Carbon, H13)					G4, F8 (option: F8 Carbon, H13)					G4					G4								
Extract filter	G4																							
Connected air duct diameter [mm]	Ø 100																							
Weight [kg]	31					31					31					31								

DESIGN AND OPERATING PRINCIPLE

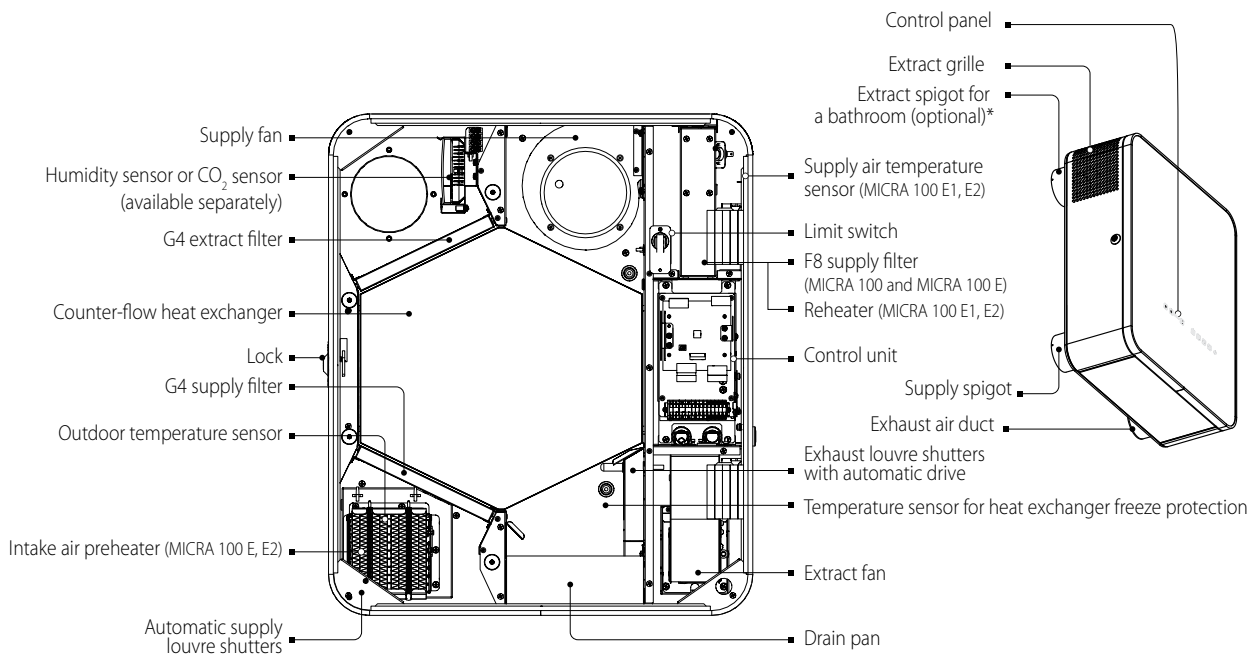

Warm stale extract air from the room flows to the unit, where it is filtered by the extract filter, then air flows through the heat exchanger and is exhausted outside by the extract fan.

Cold fresh air from outside flows into the unit, where it is cleaned by the supply filter. Then filtered air flows through the heat exchanger and is moved to the room with the supply fan.

Thermal energy of warm extract air is transferred to clean intake fresh air from outside and warms it up. The air flows are fully separated. Heat recovery minimizes heat losses, which reduces the cost of space heating in the cold season.

Depending on the model the unit is equipped with a supply air preheater or reheater with overheating protection.

The Micra 100 E Wi-Fi, Micra 100 E2 Wi-Fi units are equipped with a preheater.

The preheater is located upstream of the heat exchanger and is designed for its freeze protection.

The Micra 100 E1 Wi-Fi, Micra 100 E2 Wi-Fi units are equipped with a reheater.

The reheater is located downstream of the heat exchanger and is designed for extra heating of supply air to more comfortable temperature.

When the intake air temperature is below -3°C , the preheater automatically warms up intake air so the average exhaust air temperature downstream of the heat exchanger is not below $+5^{\circ}\text{C}$.

The reheater is switched on and off by means of a button on a sensor control panel, a remote control or via mobile application.

The heat exchanger freeze protection in Micra 100 Wi-Fi and Micra 100 E1 Wi-Fi unit models without a preheater is achieved by automatic supply fan speed reduction according to extract air sensor readings.

The extract fan runs at maximum speed.

Temperature differences between supply and extract air flows in units with polystyrene heat exchangers lead to condensate formation. Condensate is collected in the drain pan and is removed outside by the drain pipes through the exhaust air duct.

Condensate is not formed in units equipped with an enthalpy heat exchanger as moisture is transferred from one air flow to another through a membrane.

The louvre shutters open automatically when the motors are switched on and close when the motors are switched off.

*An additional extract spigot can be fitted to the unit to connect the exhaust air duct from additional premises, e.g. a bathroom.

The spigot is included in the delivery set.

INSTALLATION AND SET-UP



READ THE USER'S MANUAL BEFORE INSTALLING THE UNIT.



WHILE INSTALLING THE UNIT ENSURE CONVENIENT ACCESS FOR SUBSEQUENT MAINTENANCE AND REPAIR.

Minimum distances from the unit to the surfaces

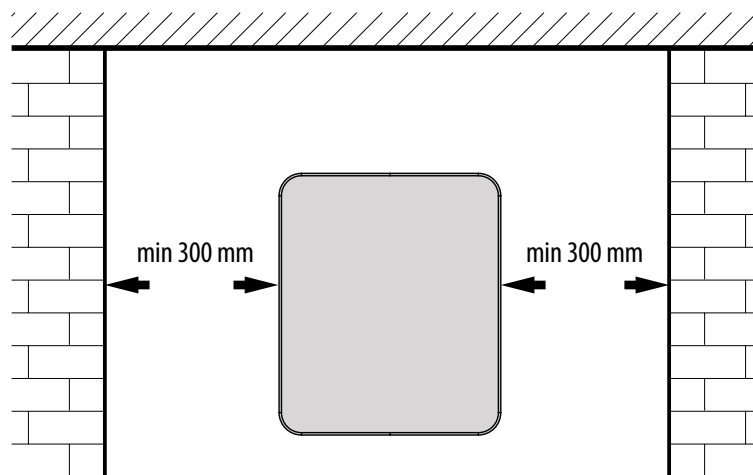

Hole spacing template

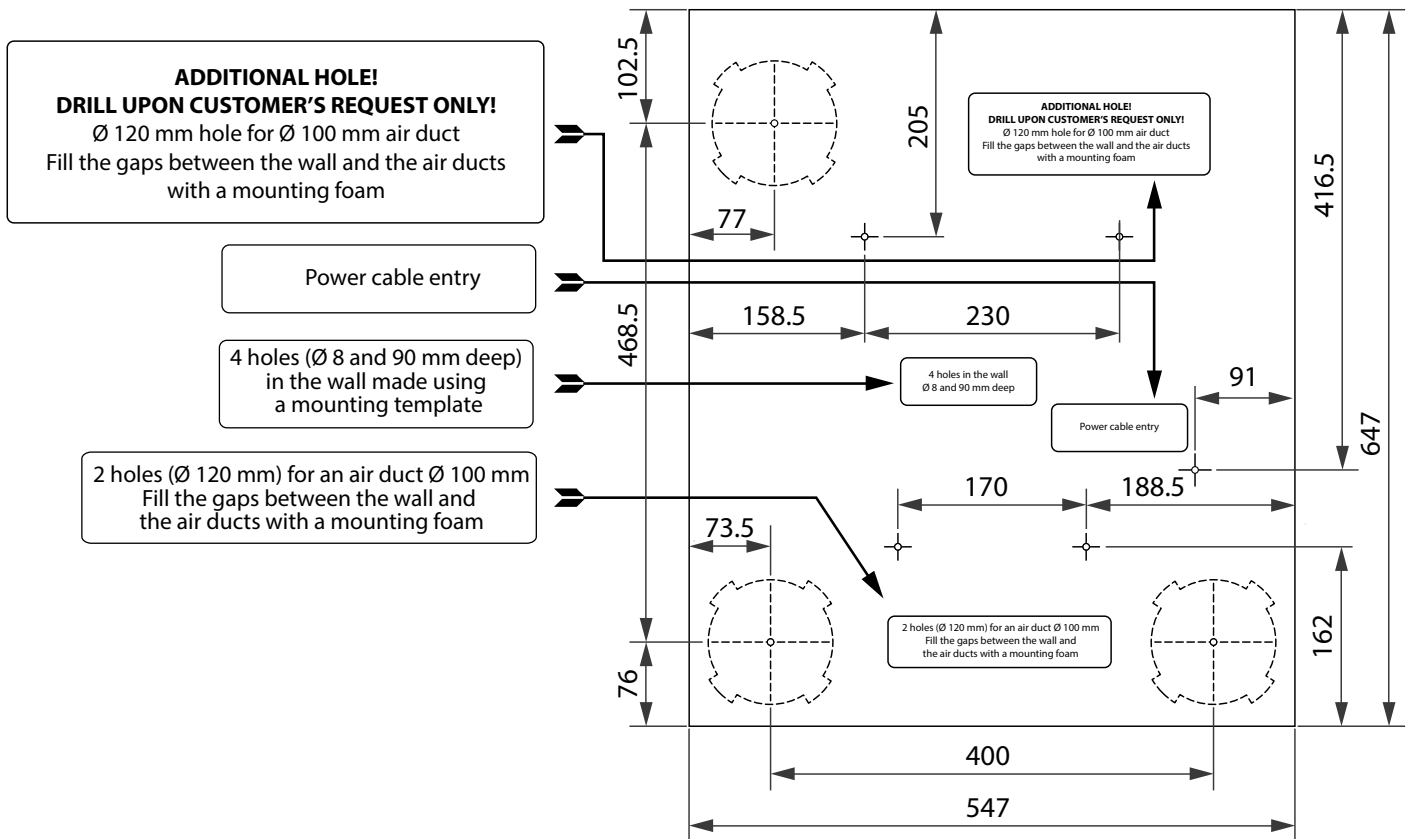

Unit mounting



BEFORE MOUNTING MAKE SURE THE CASING DOES NOT CONTAIN ANY FOREIGN OBJECTS (E.G. FOIL, PAPER).



**THE UNIT MUST BE MOUNTED ON A PLANE SURFACE.
 MOUNTING OF THE UNIT TO AN UNEVEN SURFACE CAN LEAD TO THE UNIT CASING DISTORTION AND OPERATION DISTURBANCE.**

1. Mark and drill holes in the wall using a mounting template.
 Fix the mounting template at the required level on the wall with a self-adhesive tape.
 Using a mounting template make marks to drill holes for air ducts, for unit mounting and for power cable entry.
 Before installation operations route necessary cables and wires to the unit mounting place.

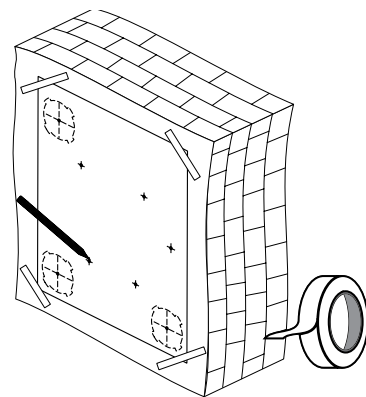

2.1. Remove the mounting template and drill two through holes \varnothing 120 mm for round air ducts. When mounting the unit with an additional extract spigot prepare a hole in the wall for a connecting bend and for laying of a rectangular air duct. A connecting bend, rectangular and round air ducts are available separately. Drill holes (\varnothing 8 mm, 90 mm deep) to mount the unit. Install the expansion anchors, remove the perforated fillers for the air ducts from the mounting template and install the mounting template back using a self-adhesive tape.

2.2. Cut air ducts of required length. Note that the telescopic air duct end must protrude for the distance that enables installation of the outer ventilation hood. For details, refer to the installation instruction for the ventilation hood. The outer ventilation hood is available separately.

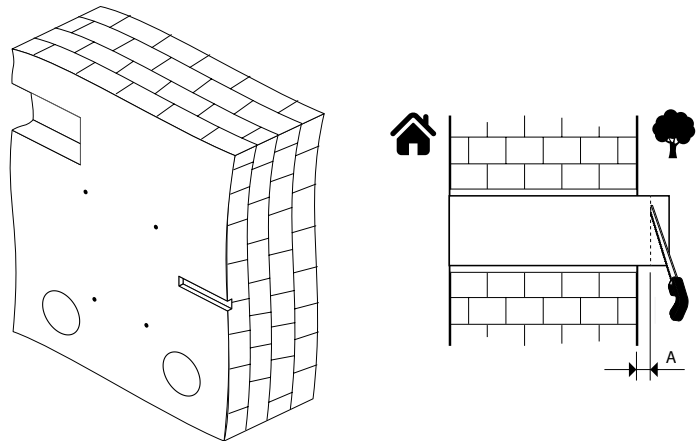

3. Fix the mounting template on the wall to install the air ducts.

Insert the air ducts in the corresponding holes of the mounting template.

Install the air duct with the minimum slope of 3 mm for condensate removal.

To install the unit with an additional spigot, insert the connecting bend into the prepared hole in the wall, aligning the mounting template hole with a round end of the connecting bend.

Connect a rectangular duct to the connecting bend.

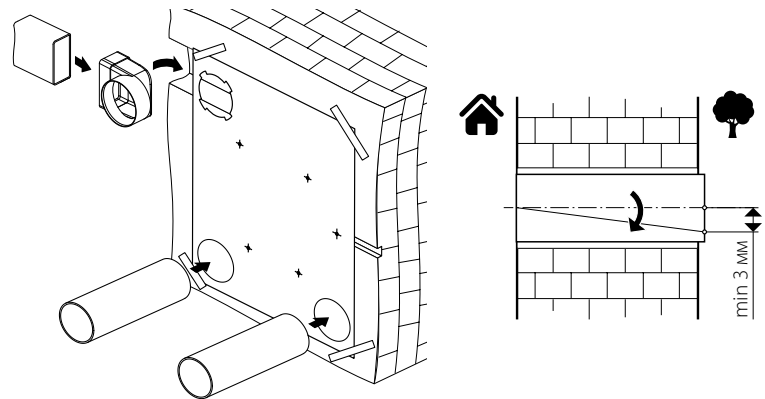

4. Fill the spaces between the air ducts and the wall with a mounting foam through the specially designed holes in the mounting template.

Wait till the mounting foam hardens then take off the mounting template and remove the foam excess.

Cut off the protruding air duct parts to be flush with the wall surface.

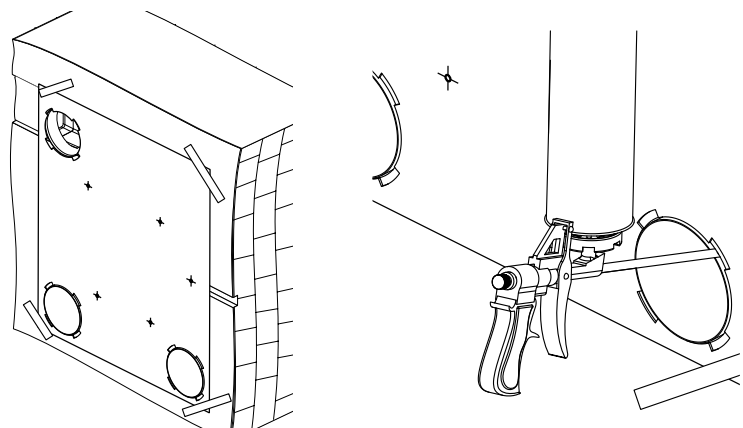

5. To install an additional extract spigot, remove the plug on the rear part of the unit. Undo the screws, remove the plug and fix a spigot on its place using screws.

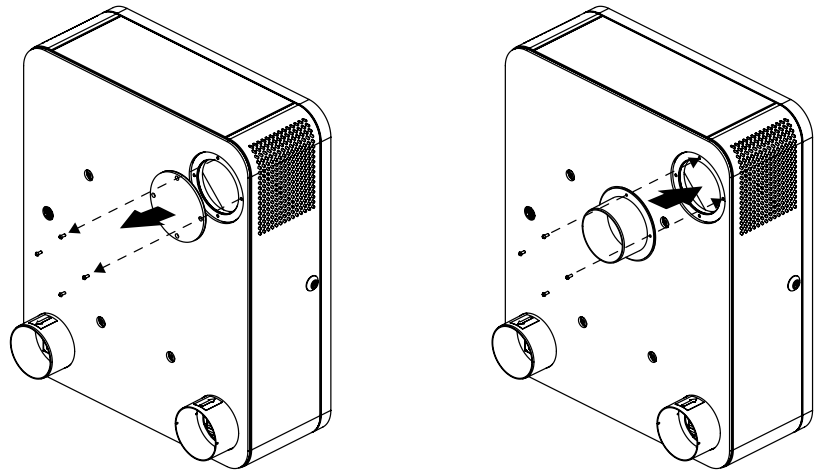

6. Caution! Install the condensate preheater before fixing the unit to the wall (see the Installation manual of the heater).

Insert the connecting cables of the heater, external humidity sensor or CO₂ sensor into the control unit through the corresponding holes on the back wall of the unit.

- Open the unit, undo the fixing screws and remove the heat exchanger.
- Lift the unit and insert the spigots into the corresponding air ducts installed in the wall.

Caution! Remove the magnetic plug from the exhaust grille if an additional extract spigot is not installed.

- Fix the unit on the wall using the supplied screws and dowels.
- Install the heat exchanger back to the unit.
- Install the humidity or CO₂ sensor (available separately) on the bracket.
- Make electrical connections, see "Connection to power mains".
- Reassemble the unit in the reverse order.

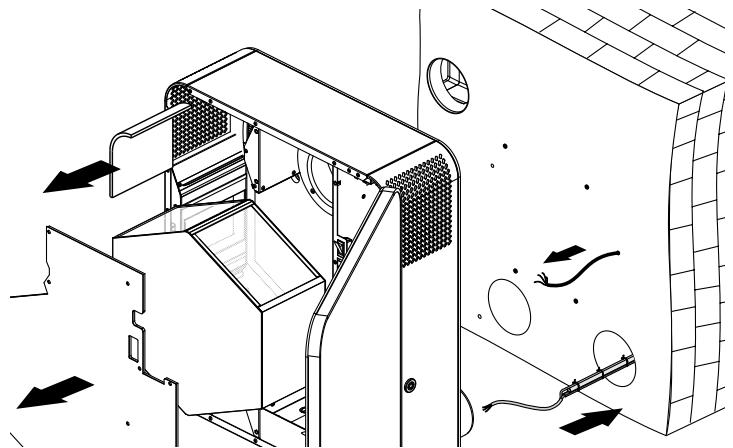

7. Install the outer ventilation hood:

- Cut a part of the drain pipe protruding outside to a length not more than 10 mm.
- Remove the foam excess.
- Fill the gaps between the air ducts with sealant.
- Fix the outer hood on the outer wall of the building (see the ventilation hood installation manual).

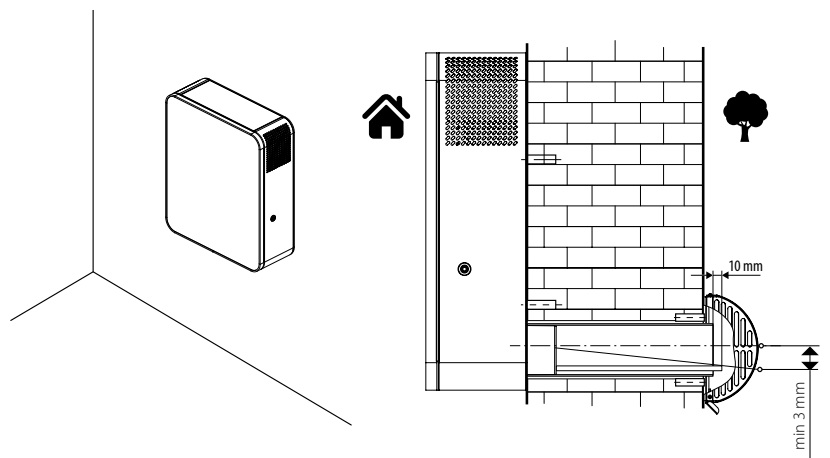

CONNECTION TO POWER MAINS



**POWER OFF THE POWER SUPPLY PRIOR TO ANY OPERATIONS WITH THE UNIT.
THE UNIT MUST BE CONNECTED TO POWER SUPPLY BY A QUALIFIED ELECTRICIAN.
THE RATED ELECTRICAL PARAMETERS OF THE UNIT ARE GIVEN ON THE
MANUFACTURER'S LABEL.**

- The unit is rated for connection to Micra 100... 1~110-240 V/50 (60) Hz / Micra 100 E... 1~230 V/50 (60) Hz power mains.
- The unit must be connected to power mains using insulated electric conductors (cables, wires). The actual wire cross section selection must be based on the maximum load current, maximum conductor temperature depending on the wire type, insulation, length and installation method.
- The external power input must be equipped with an automatic circuit breaker built into the stationary wiring to open the electric circuit in case of overload or short-circuit. The circuit breaker installation place must provide quick access for emergency shutdown of the unit. The trip current of the automatic circuit breaker **QF** must exceed the maximum current consumption of the unit (refer to the technical data table). The recommended trip current of the circuit breaker is the next current in the standard trip current row following the maximum current of the connected unit. The automatic circuit breaker is not included in the delivery set.

Wiring diagram of the additional controls in the control unit

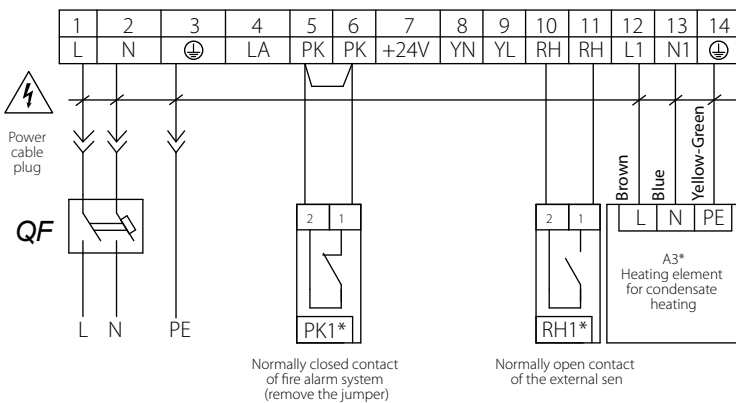

Connection of additional external control contacts is implemented in the control unit. For accessing the control unit open the unit door, release the screws fixing the shielding and remove it.

Wiring diagram of the CO₂ sensor inside the unit

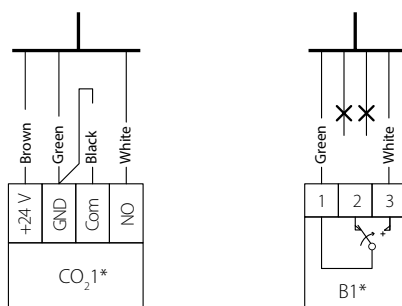

Connecting humidity sensor or CO₂ sensor to the control unit via a cable, which is attached to the bracket

Designation	Name	Type	Cable
PK1*	Contact from fire alarm panel	N.C.	2x0,25 mm ²
RH1*	External sensor contact	N.O.	2x0,25 mm ²
A3*	Heating element for condensate heating		3x0,75 mm ²
B1* or CO ₂ *	Connecting contact humidity or CO ₂ sensor via cable		

 - Electric shock hazard!

* not included in the delivery set.

CONTROL

The unit is controlled by means of a control panel on the unit casing, a remote control or via mobile application.

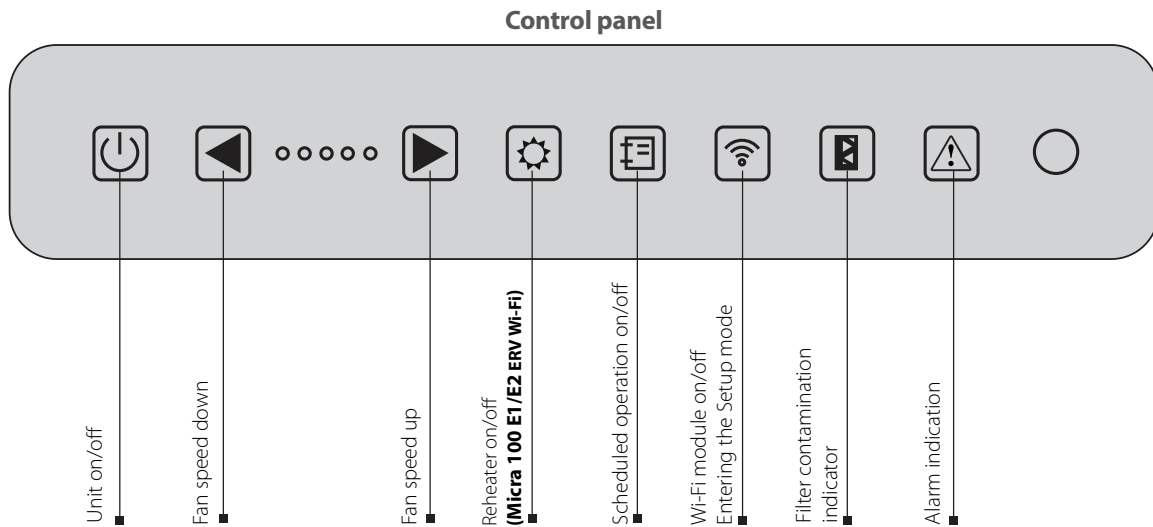

1. The unit is switched on/off using .

2. Ventilation modes can be controlled by the  and  buttons.

The  and  buttons change the ventilation mode within five speeds.

Pressing  and  simultaneously for more than 3 seconds switches the timer on/off. The time of the timer and the speed to which the installation proceeds while the timer is running is adjusted via the mobile application.

3. The reheater is switched on/off using .

4. The weekly schedule can be switched on/off by pressing the  button.

For this mode, the time must be correctly set via the mobile application.

By default, the controller stores a weekly schedule with factory settings.

The button for switching on the weekly schedule blocks the buttons for changing speeds and switching the reheating on/off.

5. The Wi-Fi module is switched on/off using .

Switch the Wi-Fi module on/off by pressing . If the button is held down for more than 5 seconds, its backlight flashes and the controller goes to the «**Setup Mode**» (for more information on this mode, see page 16).

6. At the end of the filters' service life, the filter replacement indicator  on the control panel will light up notifying that filters need to be changed.

CAUTION! After switching off the unit with the heater running, the fans continue to operate in order to cool the heater. The turn-off delay time of the fans is 0.5-2 minutes depending on the unit model.

7. In emergency situations, the unit turns off and the  indicator flashes an alarm code.

Alarm code	Alarm description
— — — — —	Outside temperature sensor missing
— — — — •	Short circuit of the outside air temperature sensor
— — — — • —	Sensor missing downstream of the reheater
— — — • •	Short circuit of the sensor downstream of the reheater
— — • — —	Extract air temperature sensor missing (upstream of the heat exchanger)
— — • — •	Short circuit of the exhaust air temperature sensor
— — • • —	Exhaust air temperature sensor missing (downstream of the heat exchanger)
— — • • •	Short circuit of the sensor downstream of the heat exchanger in the exhaust air duct
— • — — —	Reserved
— • — — •	Reserved
— • — • —	Sensor missing downstream of the heat exchanger in the supply air duct
— • — • •	Short circuit of the sensor downstream of the heat exchanger in the supply air duct
— • • — —	Low battery. The weekly schedule function will not work correctly
— • • • •	Reserved
— • • • —	Fire alarm activation
— • • • •	Error of connection between the control panel and the controller (not indicated in the mobile application)
• — — — —	Wi-Fi module initialization error
• • • • •	Unknown error (if this error occurs, contact the customer service)

• – short light signal

— – long light signal

You may find a detailed alarm description in a mobile application.

Remote control

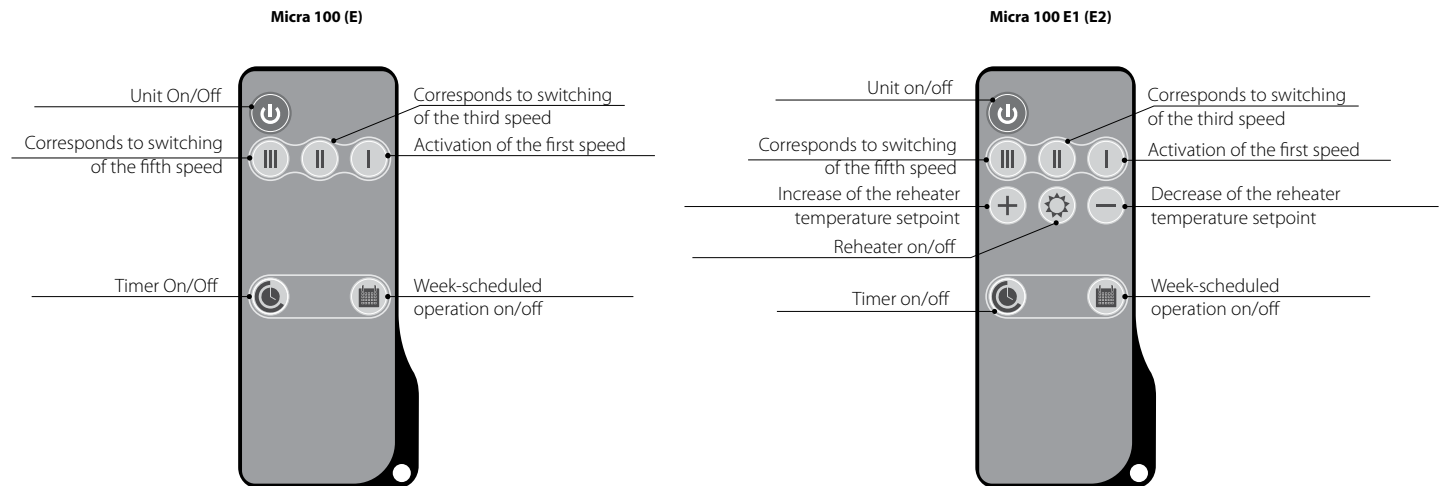

UNIT CONTROL VIA THE APPLICATION ON THE MOBILE DEVICE

Unit control is carried out using the **Vents Home** app on the mobile device.
The application is available for download at App Store, Play Market or via the QR code.

[Vents Home – App Store](#)

[Vents Home – Play Market](#)

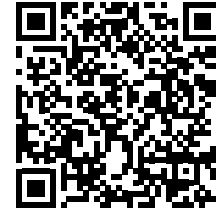
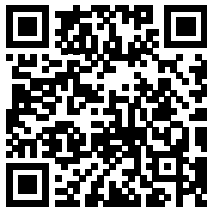

WI-FI TECHNICAL DATA

Standard	IEEE 802,11, b/g/n
Frequency band [GHz]	2,4
Transmission power [mW] (dBm)	100(+20)
Network	DHCP
WLAN safety	WPA, WPA2

By default, the unit operates as a Wi-Fi access point.
After installing the application, connect the mobile device to the unit as to a Wi-Fi access point (FAN: + 16 characters of the ID number) indicated on the control board and on the unit casing.
Wi-Fi access point password: 11111111 (eights ones).
The units can be controlled using the mobile app via a cloud server connection.

SPECIAL SETUP MODE

In the event of losing the Wi-Fi password or the unit password, connecting external devices or in other cases use the special Setup mode to restore access to the unit functions.
To enter the special Setup mode, press and hold the Wi-Fi button on the control panel for 5 seconds before the LED on the button starts flashing.
The unit will continue in this mode for 3 minutes and then will automatically revert to the previous settings.
To exit the Setup mode, press and hold the button again for 5 seconds until the LED on the button stops flashing.

Settings in the special Setup mode

Wi-Fi name: Setup mode.
Wi-Fi password: 11111111.
The unit password is ignored.

BASIC MODES

Standby mode: this mode turns off the unit. Provides for fans complete stop blocking. Air flow of the fans is configured in the engineering menu. If air flow greater than 0% is selected in this mode, the temperature will not be controlled at the setpoint.

Boost mode: activated after sending a signal to the corresponding discrete input on the control circuit board. Has lower priority than **Timer** and **Standby** modes. There is a mode activation delay of 0 to 15 minutes (0 minutes by default) after the signal is sent to the digital input. There is also a mode deactivation delay of 0 to 60 minutes (0 minutes by default) after the signal on the digital input is lost. Air flow settings for supply and exhaust fans are available in the engineering menu (100% by default).

Timer mode: activated using a mobile app or remote control. Has higher priority than **Standby**, **Boost** and **Schedule** modes. This mode has duration, speed and temperature settings available.

Schedule mode: activated using a mobile app or remote control. Has the lowest priority. To set up a weekly schedule, there are 4 time intervals available for each day of the week. Duration of each time interval is configurable and both speed and temperature are selectable. Adjustment can be made separately for every day, weekdays, weekends or for the whole week. For the Schedule mode to work properly, make sure that the date and time are set correctly.

Filter

Filter timer setting is available. When the set time (70-365 days) has elapsed, the filter change indicator appears and filter replacement information is displayed in the Alarms menu. This timer can be turned off. If the unit is equipped with filter contamination pressure switches, after the timer is turned off filter contamination control will be carried out only by the pressure switches.

ENGINEERING MENU

Note: the engineering menu requires expert skills.

Inadvertent changes to the engineering menu parameters may cause AHU malfunction.

By default the password is 1111.

Air flow

This menu section enables setting the air flow values for the Standby mode, speed 1-5 pre-sets as well as the **Boost** mode..

Sensors

Boost switch. If this input is enabled, the Boost mode is activated on receiving a signal to this input (on).

Fire alarm sensor. Make sure that the fire alarm sensor is connected before enabling this input. A loss of signal at this input (off) triggers an alarm condition and causes the unit to shut down.

Main heater/preheater thermostat. If the respective heater is active, a loss of signal at these inputs (off) triggers an alarm condition and causes the AHU to shut down.

Alarm/Warning Codes

Ordering No.	Description
2	Alarm! Outdoor air temperature sensor missing.
3	Alarm! Short circuit of the outdoor temperature sensor.
4	Alarm! Supply air temperature sensor missing.
5	Alarm! Short circuit of the supply air temperature sensor.
6	Alarm! Extract air temperature sensor missing (upstream of the heat exchanger).
7	Alarm! Short circuit of the extract air temperature sensor (upstream of the heat exchanger).
8	Alarm! Exhaust air temperature sensor missing (downstream of the heat exchanger).
9	Alarm! Short circuit of the exhaust air temperature sensor (downstream of the heat exchanger).
10	Alarm! Actuation of the protecting pre-heater thermostat.
11	Alarm! Actuation of the main heater thermostat.
23	Warning! Low battery. The weekly schedule function will not work correctly
25	Alarm! Fire alarm activation.
40	Warning! The filter replacement timer has expired. The filter must be replaced.
50	Alarm! No connection between the control panel and the controller.
51	Alarm! Additional supply air temperature sensor missing upstream of the main heater.
52	Alarm! Short circuit of the additional supply air temperature sensor upstream of the heater.

TECHNICAL MAINTENANCE



DISCONNECT THE UNIT FROM POWER SUPPLY BEFORE ANY MAINTENANCE OPERATIONS!

MAKE SURE THE UNIT IS DISCONNECTED FROM POWER MAINS BEFORE REMOVING THE PROTECTION

Maintenance operations of the unit are required 3-4 times per year. Maintenance includes periodic dust removal from surfaces, cleaning and replacement of filters and dry cleaning of fans.

Maintenance includes general cleaning of the unit and the following operations:

1. Filter maintenance (3-4 times per year).

Dirty filters increase air resistance in the system and reduce supply air volume.

Remove the clogged filters from the unit.

Clean the F8 filter with a vacuum cleaner.

To remove the G4 filters for cleaning remove the flexible clamps fixing them and pull the filters until they slide off the guides. Clean the filters with water and let them dry. After complete drying reassemble the filters in the reverse order.

Install the filters back to the unit.

The filters require cleaning not less than 3-4 times per year.

For new filters contact the Seller.

2. Heat exchanger maintenance (once a year).

Some dust may accumulate on the heat exchanger block even in case of regular maintenance of the filters.

To maintain the high heat recovery efficiency, regular cleaning is required.

Periodical dry cleaning is recommended. Use a vacuum cleaner with a narrow nozzle.

Remove the clogged heat exchanger out of the unit, clean it with a vacuum cleaner and install the heat exchanger back to the unit.

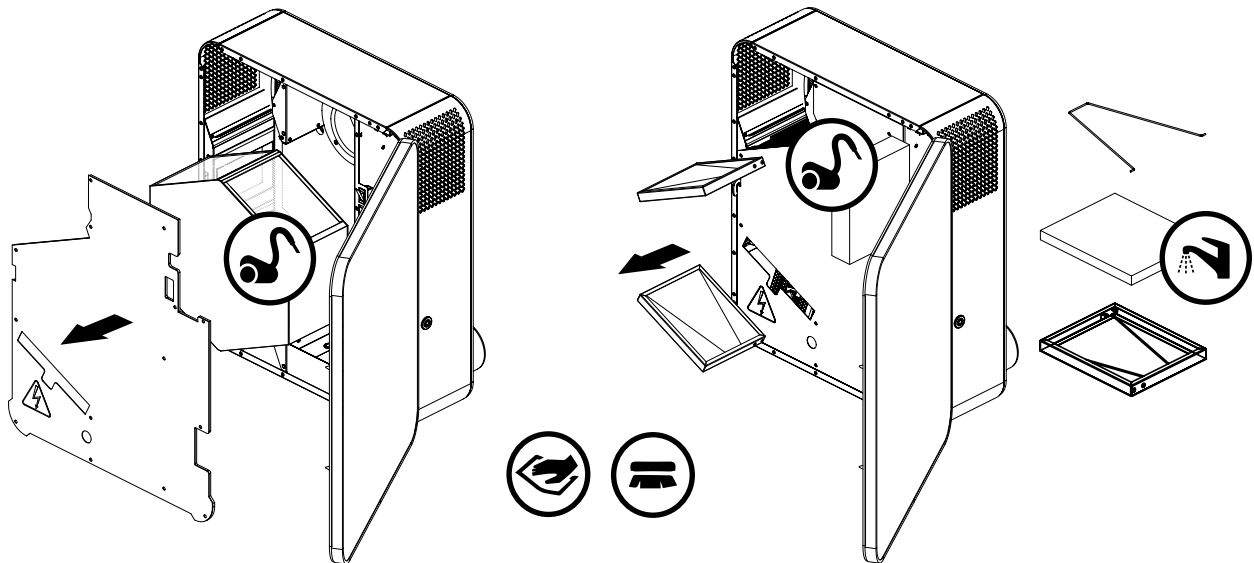

3. Fan maintenance (once a year).

Even in case of regular maintenance of the filters, some dust may accumulate inside the fans and reduce the fan performance and supply air flow.

Clean the fan with a cloth or a soft brush.

Do not use water, aggressive solvents, or sharp objects as they may damage the impeller.

4. Technical maintenance of the supply grille (twice a year).

The supply grille may get clogged with leaves and other objects which may reduce the unit performance.

Check the supply grille twice per year and clean it as required.

5. Technical maintenance of air duct system (every 5 years).

Even regular fulfilling of all the prescribed above maintenance operations may not completely prevent dirt accumulation in the air ducts which reduces the unit capacity.

Duct maintenance means regular cleaning or replacement.

TROUBLESHOOTING

PROBLEM	POSSIBLE REASONS	TROUBLESHOOTING
The fan(s) do(es) not get started.	No power supply.	Make sure that the unit is properly connected to the power mains and make any corrections, if necessary.
Cold supply air.	Extract filter clogging.	Clean or replace the extract filter.
	Heat exchanger icing.	Check the heat exchanger for icing. Stop the unit operation if necessary and wait until the ice melts.
	Heater malfunction.	Contact the Seller.
Low air flow.	The filters, fans or the heat exchanger are soiled.	Clean or replace the filters, clean the fans and the heat exchanger.
	The ventilation system is soiled or damaged.	Check for unobstructed opening of diffusers and louver shutters, check the exhaust hood and the supply grille and clean those, if necessary. Make sure the air ducts are clean and intact.
Noise, vibration.	The fan impellers are soiled.	Clean the impellers.
	The screw connection is loose.	Tighten the fastening screws.
Water leakage.	The drain pipe is clogged.	Contact the Seller.

STORAGE AND TRANSPORTATION REGULATIONS

- Store the unit in the manufacturer’s original packaging box in a dry closed ventilated premise with temperature range from +5 °C to +40 °C and relative humidity up to 70 %.
- Storage environment must not contain aggressive vapors and chemical mixtures provoking corrosion, insulation, and sealing deformation.
- Use suitable hoist machinery for handling and storage operations to prevent possible damage to the unit.
- Follow the handling requirements applicable for the particular type of cargo.
- The unit can be carried in the original packaging by any mode of transport provided proper protection against precipitation and mechanical damage. The unit must be transported only in the working position.
- Avoid sharp blows, scratches, or rough handling during loading and unloading.
- Prior to the initial power-up after transportation at low temperatures, allow the unit to warm up at operating temperature for at least 3-4 hours.

MANUFACTURER'S WARRANTY

The product is in compliance with EU norms and standards on low voltage guidelines and electromagnetic compatibility. We hereby declare that the product complies with the provisions of Electromagnetic Compatibility (EMC) Directive 2014/30/EU of the European Parliament and of the Council, Low Voltage Directive (LVD) 2014/35/EU of the European Parliament and of the Council and CE-marking Council Directive 93/68/EEC. This certificate is issued following test carried out on samples of the product referred to above.

The manufacturer hereby warrants normal operation of the unit for 24 months after the retail sale date provided the user's observance of the transportation, storage, installation, and operation regulations. Should any malfunctions occur in the course of the unit operation through the Manufacturer's fault during the guaranteed period of operation, the user is entitled to get all the faults eliminated by the manufacturer by means of warranty repair at the factory free of charge. The warranty repair includes work specific to elimination of faults in the unit operation to ensure its intended use by the user within the guaranteed period of operation. The faults are eliminated by means of replacement or repair of the unit components or a specific part of such unit component.

The warranty repair does not include:

- routine technical maintenance
- unit installation/dismantling
- unit setup

To benefit from warranty repair, the user must provide the unit, the user's manual with the purchase date stamp, and the payment paperwork certifying the purchase. The unit model must comply with the one stated in the user's manual. Contact the Seller for warranty service.

The manufacturer's warranty does not apply to the following cases:

- User's failure to submit the unit with the entire delivery package as stated in the user's manual including submission with missing component parts previously dismantled by the user.
- Mismatch of the unit model and the brand name with the information stated on the unit packaging and in the user's manual.
- User's failure to ensure timely technical maintenance of the unit.
- External damage to the unit casing (excluding external modifications as required for installation) and internal components caused by the user.
- Redesign or engineering changes to the unit.
- Replacement and use of any assemblies, parts and components not approved by the manufacturer.
- Unit misuse.
- Violation of the unit installation regulations by the user.
- Violation of the unit control regulations by the user.
- Unit connection to power mains with a voltage different from the one stated in the user's manual.
- Unit breakdown due to voltage surges in power mains.
- Discretionary repair of the unit by the user.
- Unit repair by any persons without the manufacturer's authorization.
- Expiration of the unit warranty period.
- Violation of the unit transportation regulations by the user.
- Violation of the unit storage regulations by the user.
- Wrongful actions against the unit committed by third parties.
- Unit breakdown due to circumstances of insuperable force (fire, flood, earthquake, war, hostilities of any kind, blockades).
- Missing seals if provided by the user's manual.
- Failure to submit the user's manual with the unit purchase date stamp.
- Missing payment paperwork certifying the unit purchase.



FOLLOWING THE REGULATIONS STIPULATED HEREIN WILL ENSURE A LONG AND TROUBLE-FREE OPERATION OF THE UNIT



USER'S WARRANTY CLAIMS SHALL BE SUBJECT TO REVIEW ONLY UPON PRESENTATION OF THE UNIT, THE PAYMENT DOCUMENT AND THE USER'S MANUAL WITH THE PURCHASE DATE STAMP

CERTIFICATE OF ACCEPTANCE

Unit Type	Heat recovery air handling unit
Model	
Serial Number	
Manufacture Date	
Quality Inspector's Stamp	

SELLER INFORMATION

Seller	
Address	
Phone Number	
E-mail	
Purchase Date	
This is to certify acceptance of the complete unit delivery with the user's manual. The warranty terms are acknowledged and accepted.	
Customer's Signature	

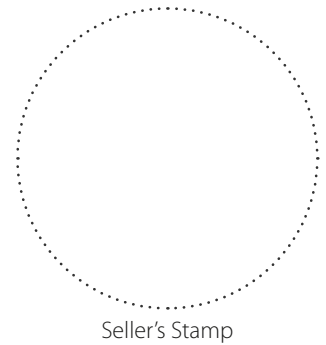

INSTALLATION CERTIFICATE

The _____ unit is installed pursuant to the requirements stated in the present user's manual.	
Company name	
Address	
Phone Number	
Installation Technician's Full Name	
Installation Date:	Signature:
The unit has been installed in accordance with the provisions of all the applicable local and national construction, electrical and technical codes and standards. The unit operates normally as intended by the manufacturer.	
Signature:	

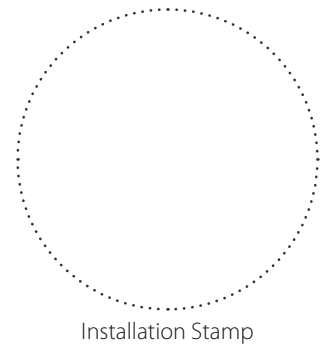

WARRANTY CARD

Unit Type	Heat recovery air handling unit
Model	
Serial Number	
Manufacture Date	
Purchase Date	
Warranty Period	
Seller	

